

## XE70 SERIES

## T6372/T6373 FAN-COIL THERMOSTATS 2-PIPE FAN-COIL CONTROL

### PRODUCT DATA

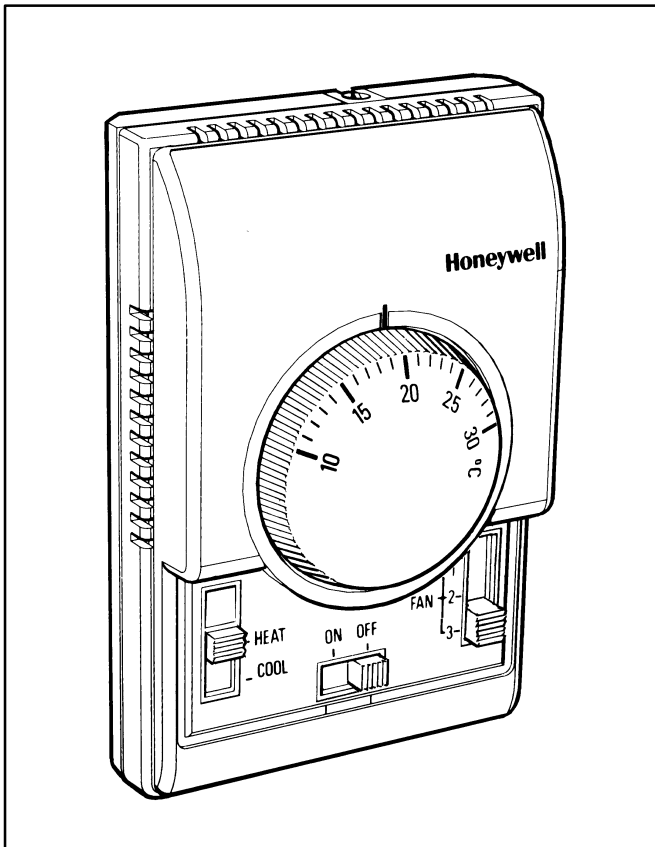

The T6372 and T6373 are designed to control the valve, or the valve and the fan in 2-pipe fan-coil applications.

The thermostat operates an on/off valve to provide control at the desired setpoint temperature.

The fan can also be controlled from the thermostat. In some cases it is wired to run continuously, and can be switched off with the system ON/OFF switch, while with other models there is a choice of running the fan continuously, or cycling it with the thermostat.

Versions are available with a manual 3-speed fan switch, and with a system on-off switch.

Heat/cool changeover operation is also possible on some versions. This function can be accomplished either by a manually operated heat/cool switch on the front of the thermostat or in some versions automatically by the use of a pipe thermostat on the supply water pipe of the fan-coil.

## FEATURES

- Dual diaphragm sensing element ensures close temperature control for all loads and applications
- Attractive modern styling makes this thermostat ideal for locating in the occupied space, particularly in offices or hotels
- All versions have heat anticipator, which improves temperature control in both heating and cooling operation
- Thermostat mounts directly onto a wall or conduit box
- Slide switches allow manual control of system operation and fan speed
- Auto heat/cool changeover possible (on some versions) by using pipe thermostat
- Optional extras:
  - range stops
  - tamperproof cover

## SPECIFICATIONS

Model	Switches							Features	
	ON/OFF (SPST)	3-speed Fan (SPTT)	Fan/ Auto/Cont (SPDT)	Heat/Cool (SPDT)	Heat/Cool (DPDT)	Heat/Off/ Cool (DPTT)	Heat/Fan/ Cool (DPTT)	Fixed Deadband	Auto Change- over (Aquistat)
T6372A1018	✓								
T6372B1024				✓					
T6372B1032	✓			✓					
T6372C1014	✓								✓
T6373A1017	✓	✓							
T6373B1015	✓	✓		✓					
T6373B1064	✓	✓		✓					
T6373C1013	✓	✓							✓

Setpoint range : 10...30°C. By means of a large setpoint dial

Supply voltage : 230 V~, 50...60 Hz

Thermostat switch : S.P.D.T.

Performance : Typical differential 1K (heating & cooling) at 20°C at 50% load with anticipator connected

Electrical ratings : 4(2) A, 230 V~  
Typical loads are fans, zone valves and relays

Operational life : Greater than 100,000 cycles (all loads) for thermostat contacts at 230 V~  
Greater than 6,000 operations for all manually operated switches

Mounting : Mounts directly onto wall or wall-box (mounting screws supplied)

Wiring : Up to 8 screw-in terminals per unit, capable of accepting wires up to 1.5 mm<sup>2</sup>

Enclosure : Plastic 2-piece housing

Dimensions : 85 x 130 x 40 mm (w x h x d).

Protection class : IP30

RFI suppression : Provided to B.S. EN 55014

Environmental requirements : Operating temperature range 0 to 40°C  
Shipping and storage temperature range -20 to 50°C  
Humidity range 0 to 90% rh, non-condensing

Approvals : Designed to meet harmonised EC approvals standard IEC 730

## DIMENSIONS

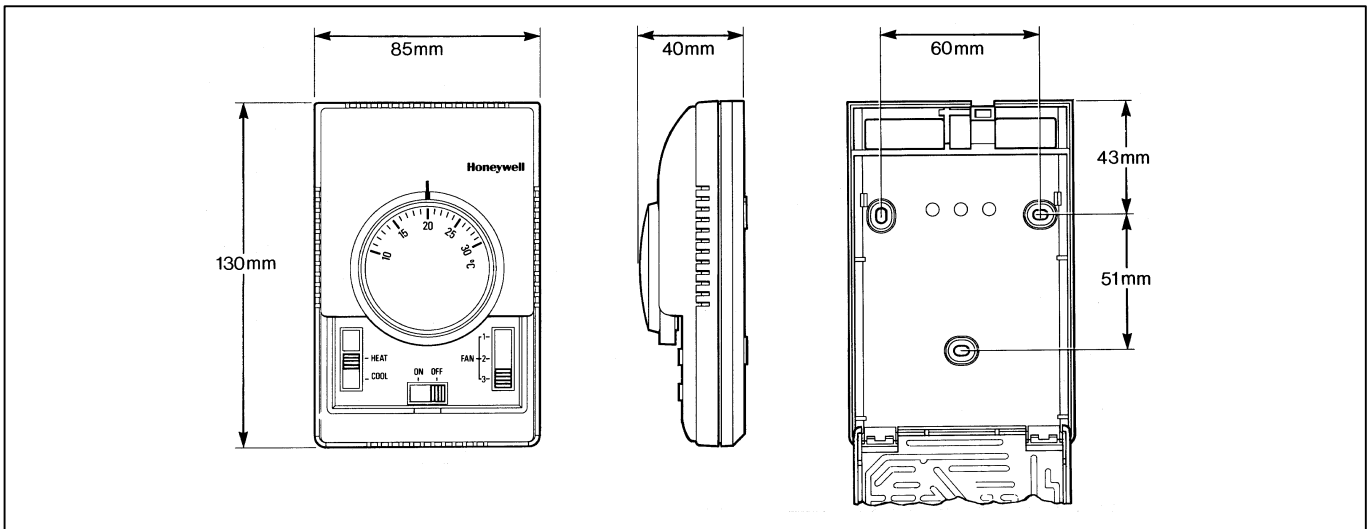

# INSTALLATION

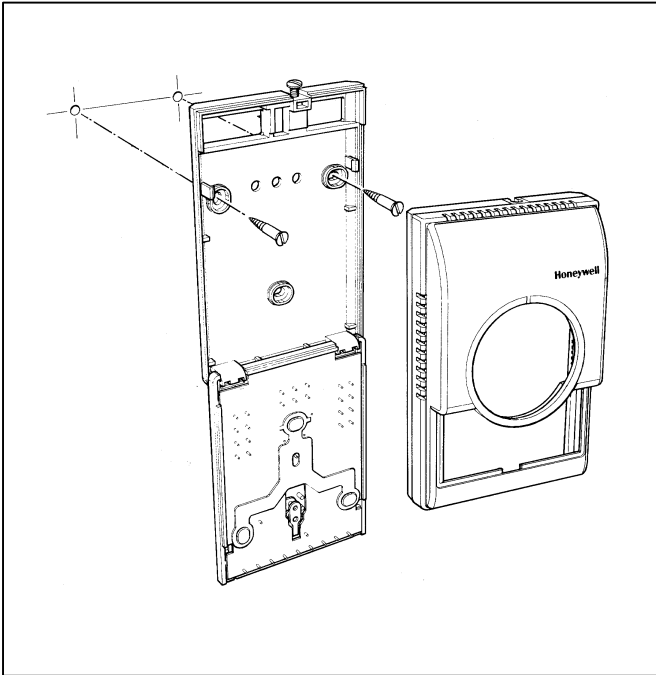

## Location

The XE70 Series thermostat is the temperature control element in the fan-coil or air-conditioning system, and must be located in a position with good air circulation, on an inside wall about 1.5 m above the floor to sense the average temperature. Do not position the thermostat in draughts, near hot or cold air sources or where it will be affected by radiant heat from the sun or other appliances.

## Mounting the thermostat

Any XE70 Series thermostat can be directly mounted on the wall or on a conduit box (see diagram). Mounting screws are supplied for both alternatives.

## Wiring the thermostat

The standard wiring access is via a hole in the base of the thermostat, near the top edge.

### IMPORTANT

1. The installer must be a trained service engineer
2. Disconnect the power supply before beginning installation

# OPERATION

## Sensing element

The thermostat sensing element comprises two circular, flexible metal plates welded together at the rims and encapsulating a gas/liquid combination whose pressure changes in response to variations in temperature. This dual-diaphragm expands and contracts with ambient temperature changes to operate a snap-acting switch which controls the heating or cooling circuit.

## Heat anticipator

It is recommended that the heat anticipator is always connected for both heating and cooling operation.

## Switches

All switches are slide switches for ease of operation.

The ON/OFF switch is a system on/off switch, as it removes power from the thermostat.

The FAN SPEED switch allows selection of 3 different fan speeds, 1 (low), 2 (medium), and 3 (high)

The SPDT HEAT/COOL switch allows selection of either heating or cooling operation. There is only a single output connection capable of powering a fan or a single zone valve in a 2-pipe fan-coil unit.

## Application

		T6372A 1018	T6372B 1024	T6372B 1032	T6372C 1014	T6373A 1017	T6373B 1015	T6373B 1064	T6373C 1013
<b>Application</b>	Ventilation 2-pipe fan-coil 4-pipe fan-coil Heatpump Air-conditioner	☞	☞ ☞	☞ ☞	☞ ☞	☞	☞	☞	☞
<b>Control Capability</b>	Heat or Cool Heat/cool Changeover (auto or manual) Fan control (auto or cont) Fan speed control Valve control Compressor control	☞  a or c  ☞	☞  manual a or c  ☞	☞  manual a or c  ☞	☞  auto a or c  ☞	☞  cont  ☞	☞  manual cont  ☞	☞  manual a or c  ☞	☞  auto cont  ☞

# WIRING

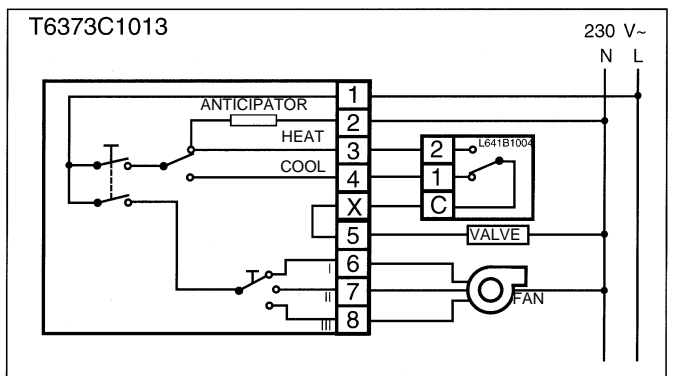
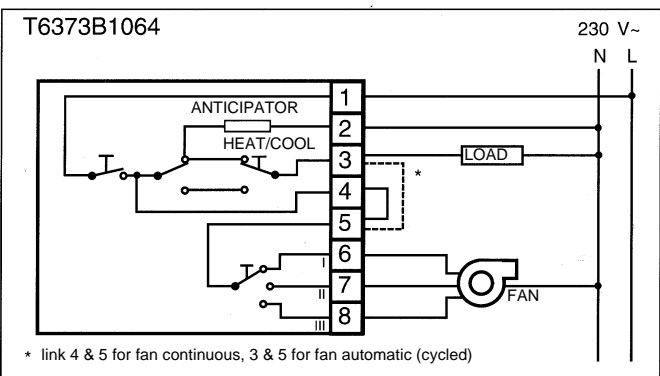
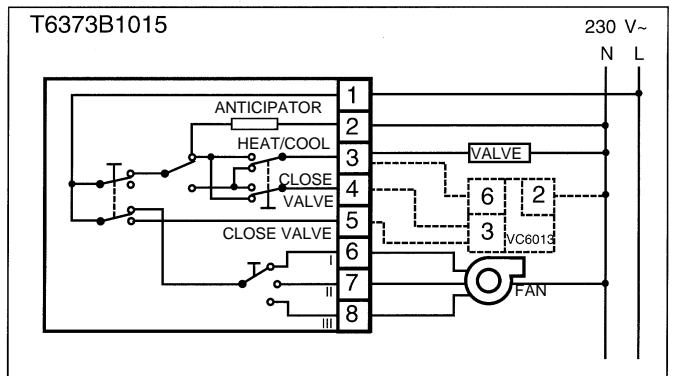
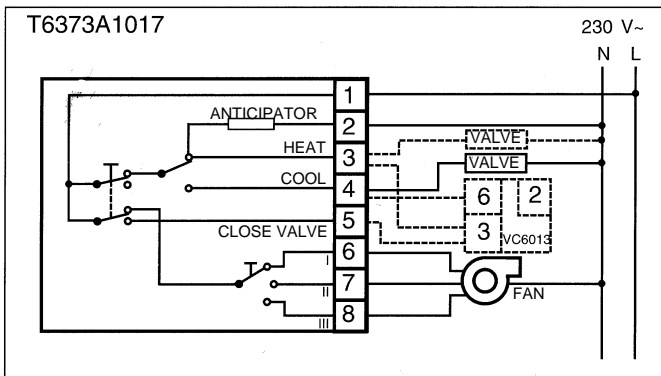
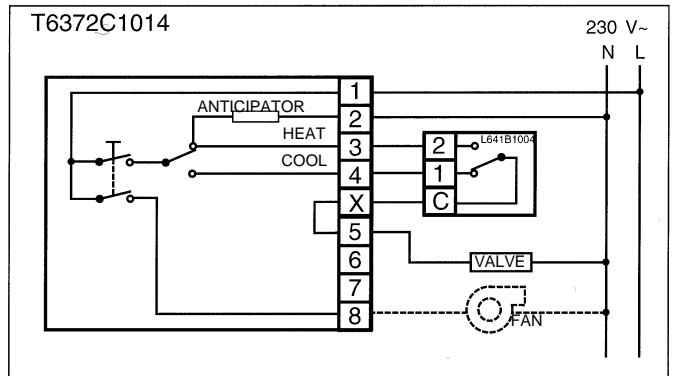
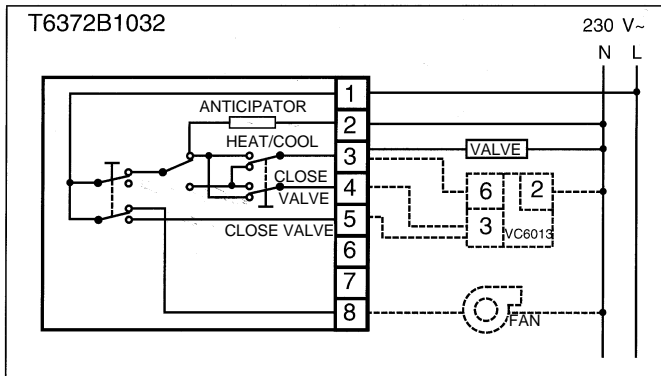
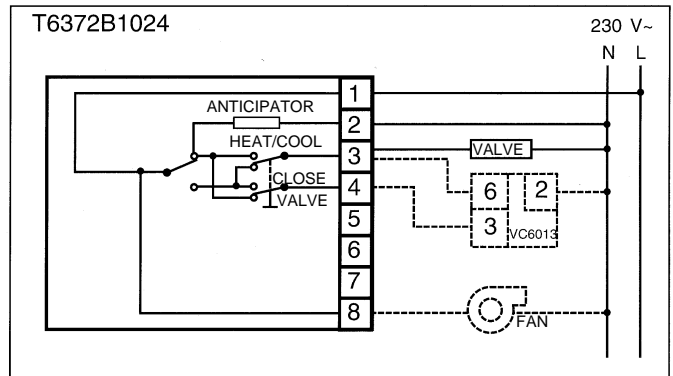
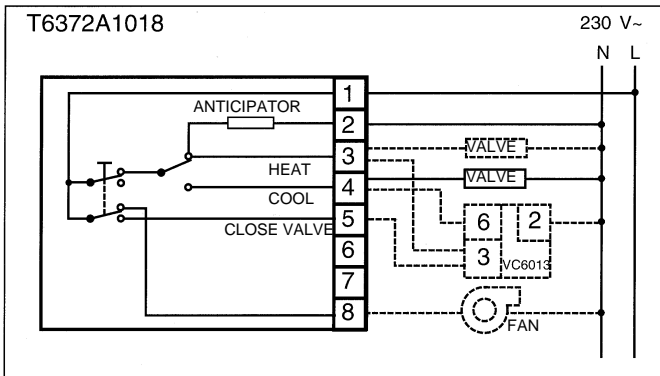

**Honeywell**

Honeywell Control Systems Limited  
Newhouse Industrial Estate  
Motherwell ML1 5SB  
United Kingdom

*Helping You Control Your World*